

DO NOT SCALE

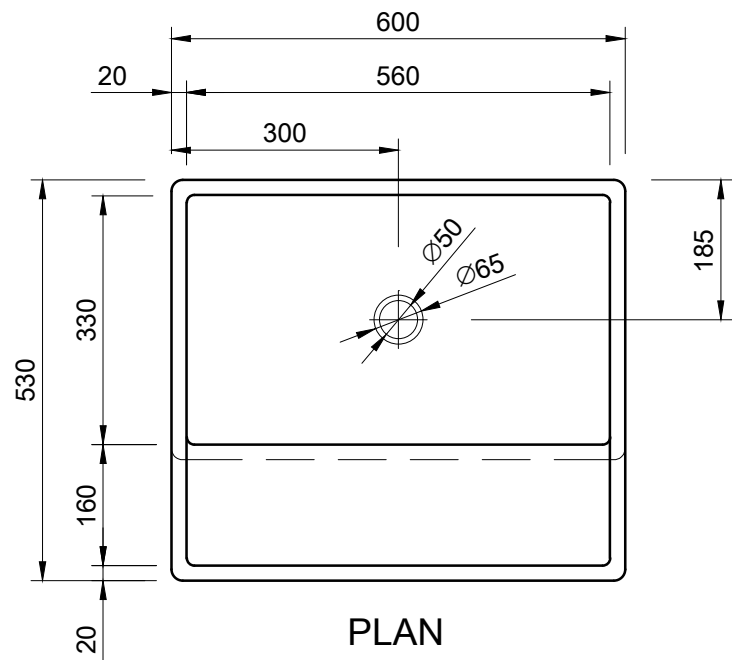

PLAN

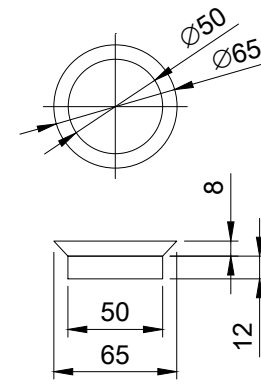
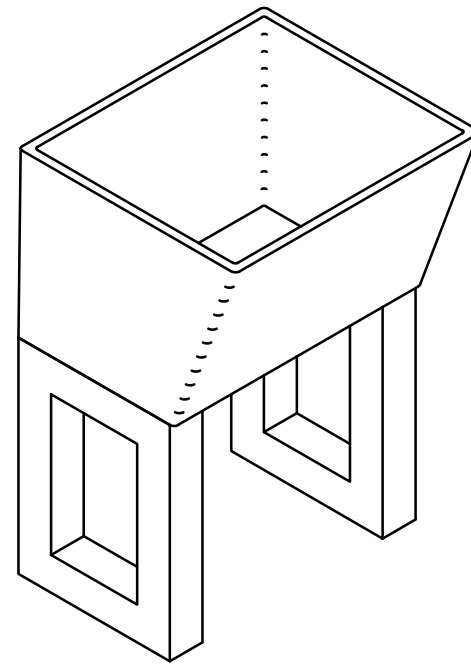

WASTE DETAIL

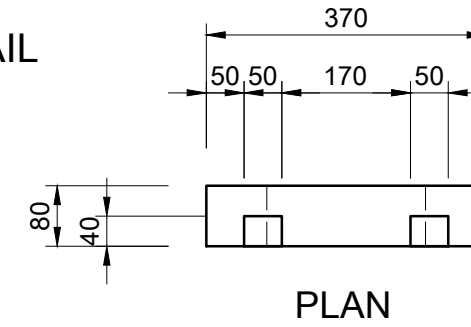

PLAN

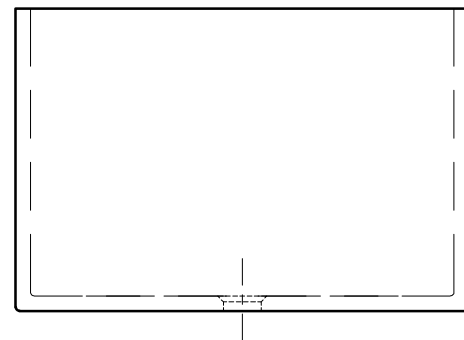

FRONT ELEVATION

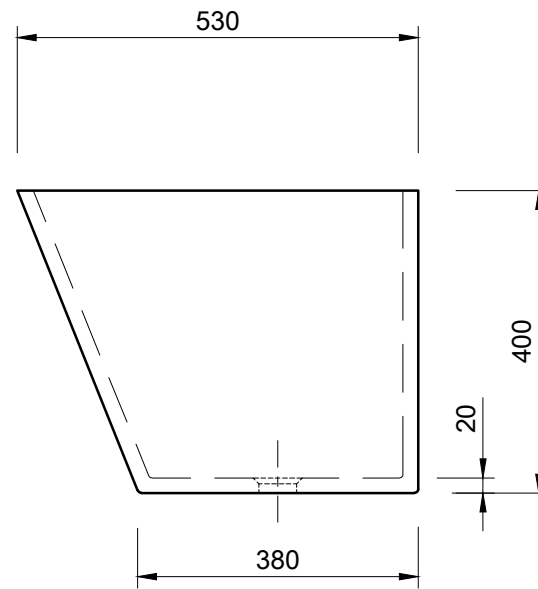

SIDE ELEVATION

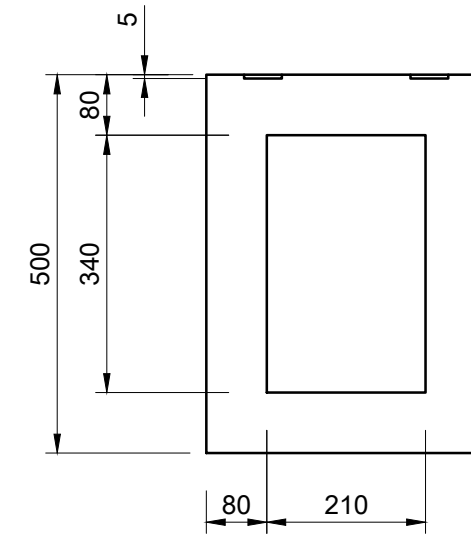

FRONT ELEVATION

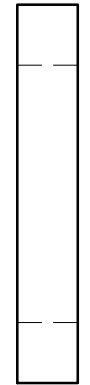

SIDE ELEVATION

TROUGH LEGS DETAILS

CONCRETE LEG WEIGHT 40kg PAIR

NOTE
LEGS ARE CONNECTED WITH 5mm FLAT BAR AT REBATES

FOR CONSTRUCTION

TROUGH DETAILS

WEIGHT OF TROUGH 55kg

DIMENSIONS IN MILLIMETERS

REV	REVISION	BY	DATE
B	NAME ADDED	TLD	03.08.2022
A	ISSUED FOR APPROVAL	TLD	29.06.21



Concrete Republic Pty Ltd

Workshop Address: 16 Naughton Ave, North Geelong. Victoria
 ABN: 80 621 646 839
 Email: admin@concreterepublic.com.au
 Phone: 0477 885 526

TITLE			
ODLA CONCRETE TROUGH & LEG DETAILS			
DRAWN	CHECKED	DRAWING No.	
T.L.DIRCKS		CR210629-01	
DATE	SCALE		
29.06.2021	NTS	REV.	
		B	